

Thermal Fogger Manual

H100, H100SF, H200 & H200SF

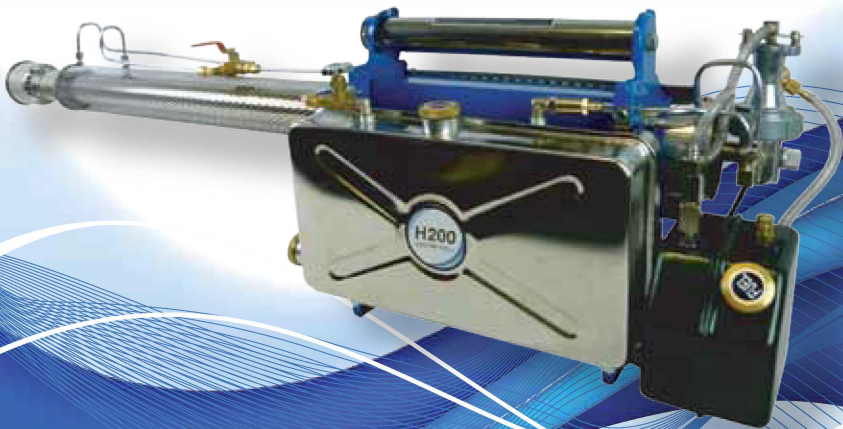



INSTRUCTION MANUAL THERMAL FOGGER VECTORFOG H100, H100SF, H200 & H200SF

When fogging outdoors, you should only fog for short periods at a time and when there is not much wind. When fogging indoors you should start at the furthest part of the building and work your way back until you get to the entrance or exit. It's essential to read the chemical manufacturer's instructions before you start applying, including diluting ratio and safety precautions. Only experienced personnel should operate this equipment. If fuel or chemicals are spilt, you should exercise caution to avoid the risk of fire or contamination. You must use protective equipment when handling this machine. Incorrect use of this equipment by unqualified personnel could result in serious risk of injury.

CAUTION MARKS



Please read this manual before using the equipment.



You must wear protective equipment (face/breathing mask, protective clothing, gloves, etc.) when handling potentially hazardous chemicals.



It is advisable to wear ear plugs to protect the user from the high noise produced by the machine



The interior of the machine heats up to extremely high temperatures Do not add fuel or chemicals during the operation of the machine or when it is hot after use.



Avoid fogging chemicals upwind.



Risk of electric shock. Do not turn on the machine when the spark plugs electrode is exposed.



SPECIFICATIONS

Model	H100 / H100SF	H200 / H200SF
Motor	Pulse Jet	Pulse Jet
Chemical Tank	Polymer	Stainless steel
Tank Size	4.5L	6.5 L
Flow rate	10-50 LPH	10-50 LPH
Pressure in the chemical tank	0.224 bar	0.224 bar
Fuel	Petrol	Petrol
Performance	19 kW	19 kW
Fuel tank pressure	0.8 bar	0.8 bar
Start	Automatic (manual version available)	Automatic (manual version available)
Fuel tank capacity	1.2 L	1.2 L
Weight(net)	8.5 Kg	10.8 Kg
Dimension	115x34x25 (cm)	133x28x38 (cm)
Features	Fuel Tank cut off switch (Model SF : Dual Function - Fog water /oil based Chemicals)	Fuel Tank cut off switch (Model SF : Dual Function - water based chemicals as well as oil based)
Accessories	Belt, Spares Kit, Charger, Toolkit, Instruction Manual	Belt, Spares Kit, Charger, Toolkit, Instruction Manual

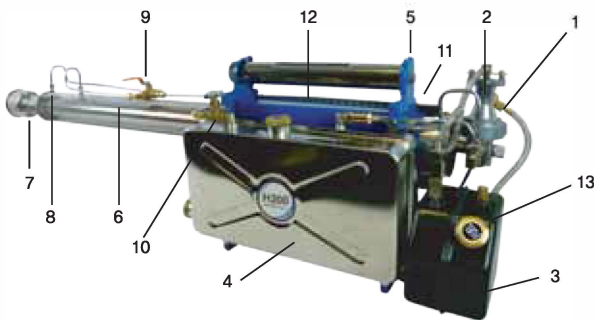

1. Fuel Injector
2. Carburettor
3. Fuel Tank
4. Chemical Tank
5. Main Body
6. Safety Mesh
7. Resonator
8. Chemical Inlet
9. Close valve/Directional valve (SF model)
10. Chemical Supply valve
11. Security Cover
12. Handle/Manual Start Pump (optional)
13. STOP button

CHECKLIST BEFORE STARTING THE UNIT



Unpacking the unit

When unpacking the unit, please make sure that the machine is not damaged and that all the accessories mentioned in this manual are not missing.



Make sure the charger is not damaged and that it is of correct voltage before plugging to the mains.



Charge the battery

Make sure the right power supply is being used (110/220 volts). Connect the charger to the unit and then connect to the mains. When first purchased, the machine requires around 8 to 10 hours to fully charge.

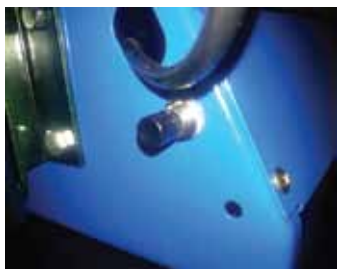

Inspect the ignition unit

Press the START button situated below the carburettor and listen to ensure that the spark plug is working to start the ignition process.



Fill the fuel tank

Fill the tank with undiluted petrol using a funnel. Do not overfill the tank. When you finish filling the tank, close the tank cap tightly. The unit operates for approximately 40 minutes with a full tank.

Important Note: Do not fill beyond 80% of its full capacity



Fill the chemical tank

Pour the special fogging chemical mixture into the chemical tank. It is important not to add more chemical mixture than it's needed. Leaving remaining chemicals in the tank after use could affect the performance of the machine in the following session as deposits may solidify. When you finish filling the tank, close the tank cap tightly.



To turn on the machine

Press the power button "START" and keep it pressed for 8 seconds after you hear combustion starting (sounds like a small explosion). It is necessary to keep the machine on for about 10 seconds to warm up before opening the chemical valves. TIP: If the machine fails to start, press the STOP button (air release) so pressure can be re-established. Press the start button again and repeat the above procedure until it starts.



Chemical supply Valve



Close Valve



Directional Valve (SF MODEL)



To start fogging

Once the machine has heated up for 10 seconds, first turn the "Close Valve" and then slowly the chemical supply valve counter clockwise. On SF models, The "Close Valve" has been replaced by a "Directional Valve" for selecting the type of solution being applied. For applying oil based solutions the valve should face the direction of the resonator. For water based solutions, the valve should be turned to its left position.



To turn off the machine

Turn the chemical supply valve clockwise to stop the supply of chemical. Keep the machine in operation for 5 seconds to help get rid-off any chemical mixture still in the system. Close the close valve and press the STOP button located on top of the fuel tank to stop the machine.

Important: You must never switch off the machine with the chemical supply valves still open. This could Cause a back-fire.

MAINTENANCE

Cleaning the Chemical Tank and Pipes

Fill the chemical tank with 25% of clean water and turn on the unit. Then open the chemical supply and close valves to flush it through. This will prevent corrosion and the accumulation of chemical deposits in the tank and pipes.

Spark Plug Maintenance

Remove the spark plug using a spanner or spark plug remover. Remove any carbon deposits between the electrode and the earth section with a wire brush. Make sure that there is a space of 3.5 mm between the electrode and the earth.



Fuel injector Maintenance

Unscrew the fuel injector situated on the side of the carburettor. Clean the injector with compressed air to remove any blockages.

Important: Never use a metallic punch to clean the injector. The injecting hole is calibrated for optimum performance

STANDARD SYSTEM



SF MODEL



Maintaining the valve petal

Unscrew the fuel filter and regulator (if applicable) before unscrewing the top of the carburettor. Check the valve for any distortions or cracks. If it's damaged, you will need to replace this part.

TIP: It's important to assemble the carburettor in the same order as it was disassembled. The distance between the petal valve and the valve plate o should be approximately 1 mm.

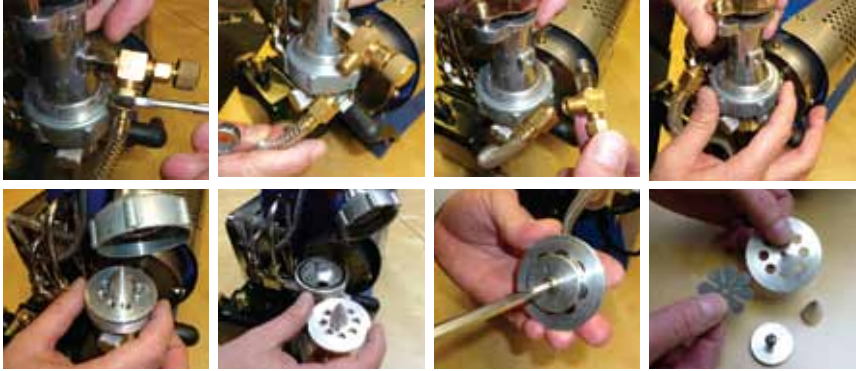

COMMON TROUBLESHOOTING

If there is no ignition:

- Listen for any noises coming from the engine

If there is noise coming from the engine but there is no ignition, this could be because the engine has flooded (an over-supply of fuel in the carburettor). Press the choke/off button above the fuel tank and then press the start button until you hear the machine ignite. Repeat this procedure several times if it doesn't start the first time.



- Check the spark plug

If there is no spark:

- ☑ Clean any carbon deposits in between the electrode and earth with a wire brush.
- ☑ Check that there is a distance of 3.5 mm between the electrode and earth.
- ☑ Check that the battery is fully charged.
- ☑ Check that the battery and ignition coil are working. If necessary, replace the battery or coil
- ☑ Clean the contacts and wires inside the battery case



Once these checks have been carried out, try starting the machine again. If the machine doesn't start replace the plug.

- Check the fuel is being injected into the carburettor.



Examine the fuel hose located on the side of the fuel tank to make sure it's not blocked. Make sure the fuel tank is full before starting the machine. Make sure the seal in the petrol cap is not damaged. Make sure the cap is firmly closed to prevent leakage. Unscrew the fuel injector from the side of the carburettor but keep it attached to the metal fuel pipe. Pointing the injector away from the machine and any people, press the start button and on each stroke of the compressor pump, fuel should be injected. If not, examine that the injector is not blocked. Do this by unscrewing the filter from the metal pipe and clean the filter with compressed air.

- Check the Petal Valve.

Remove the spark plug cap, filter and unscrew the carburettor. Examine the petal valve to see if it's damaged. If it's damaged, replace petal valve. **TIP:** It's important to assemble the carburettor in the same order as it was disassembled. The distance between the petal valve and the valve plate should be approximately 1 mm.





The machine is turned on, but the engine works intermittently or stops:

- Examine the fuel tank assembly to check for any leakages.

After pressing the start button, cover the tank and connections with soap to check for leaks. If bubbles are observed, the gasket needs replacing on the fuel tank cap or the tank itself.

- Clean the resonator.

Remove carbon deposits in the resonator with the wire brush provided. Use an forward and backward motion.



The machine doesn't fog or doesn't fog enough:

- Check that the chemical supply valve is opened. This is done by turning it anticlockwise. Make sure that the close valve is set to the open position



- Unscrew the main chemical inlet nozzle from the resonator and clean it using compressed air to remove any blockages.



- Check there is no leaks in the chemical tank. Blow compressed air backwards through the chemical tube from the inlet nozzle to see if any bubbles appear. Replace leaking parts if necessary.

PARTS ASSEMBLY

01. Resonator & chemical Inlet nozzle

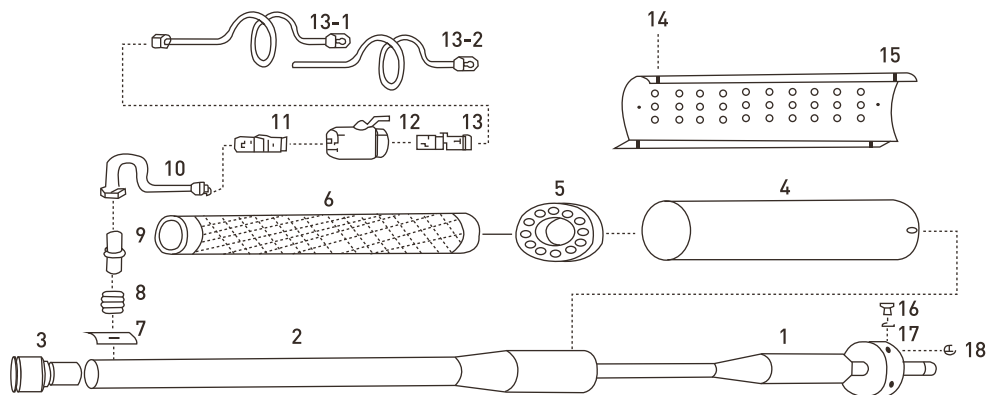

1. Ejection pipe	2. Inner cooling pipe	3. Diffuser	4. Outer cooling pipe	5. Bracket	6. Safety net
7. Ejection nipple plate	8. Ejection buffer spring	9. Ejection nipple	10. Ejection nipple tube	11. Straight nipple	12. Ball valve
13. Straight nipple	13-1. Chemical pipe	13-2. chemical pipe (SF Model only)	14. Bolt	15. Protective cover	
16. Bolt	17. Flat washer	18. Nut			

02 Pump, Frame, Ignition

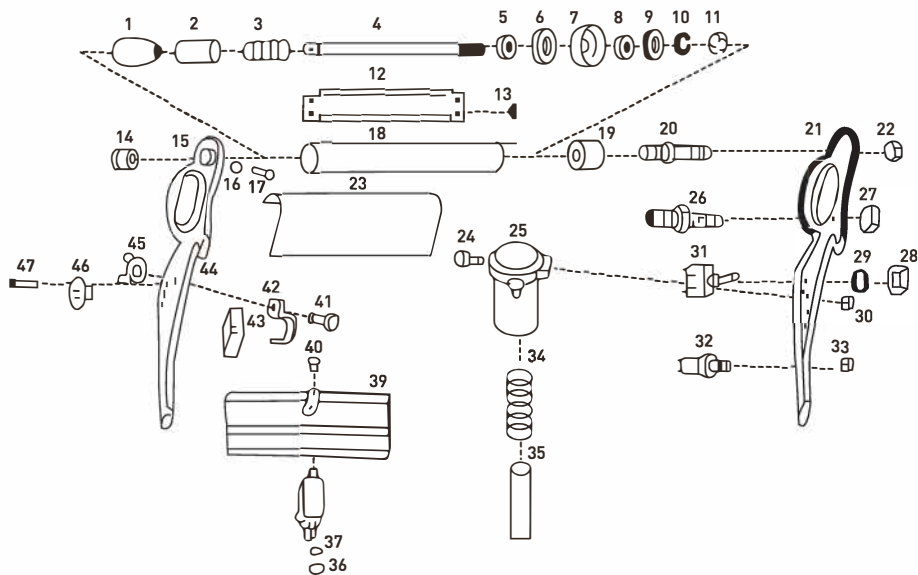

1. Handle ball	2. Buffer hose	3. Buffer spring	4. Pump shaft	5. Pump nut	6. Washer(large)
7. Pump packing	8. Washer(small)	9. Washer(medium)	10. Spring washer	11. Nut	12. Under cover
13. Piercer	14. Pump peg	15. Body(left)	16. Spring washer	17. Bolt	18. Pump(cylinder)
19. Pump rear peg	20. Hand pump hose nipple	21. Body(right)	22. Nut	23. Middle plate	24. Bolt
25. Automatic pump	26. Automatic pump air nipple	27. Nut	28. Nut	29. Washer	30. Nut
31. Toggle switch	32. Ignition switch	33. Nut	34. Hose protection spring	35. Hose	36. Nut
37. Washer	38. Ignition coil	39. Bottom plate	40. Bolt	41. Bolt	42. Battery grip
43. Battery	44. Nut	45. Butterfly nut	46. Charging consent	47. Bolt	

03. Chemical & Fuel Tank

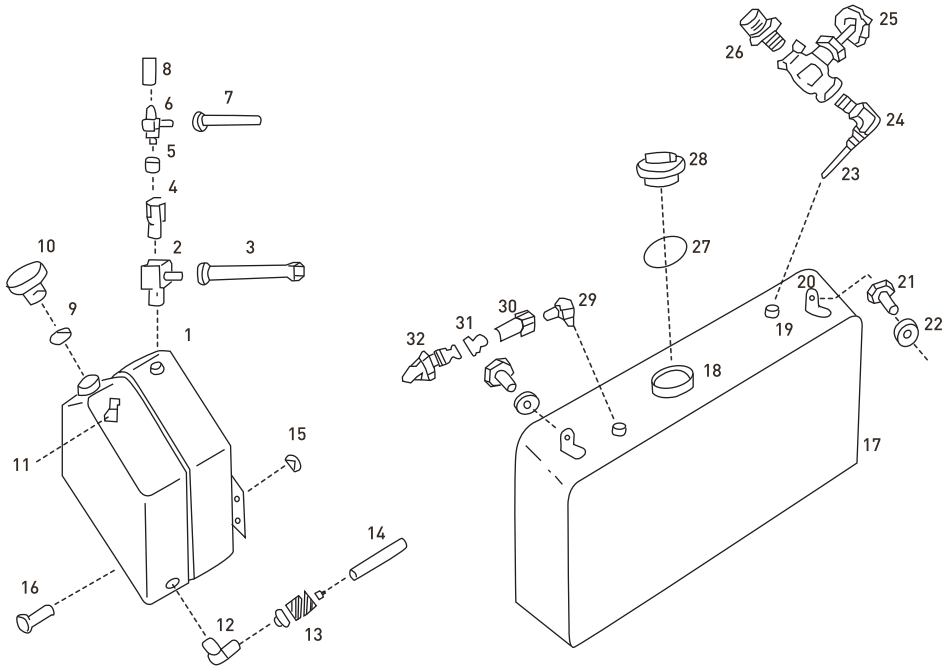

1. Fuel tank	2. Run tee	3. Fuel tank pipe	4. Check valve	5. Rubber check valve	6. T-check valve
7. upper air pipe	8. Oil pressure hose (blk)	9. O-ring	10. Oil tank peg	11. Knocking release	12. Oil tank elbow
13. oil filter device	14. fuel hose	15. nut	16. nut	17. chemical tank	18. chemical tank mouth
19. Chemical tank fitting	20. Chemical tank grip	21. Chemical tank bolt	22. Chemical tank nut	23. Chemical outlet pipe	24. Elbow
25. Chemical amount control valve	26. Straight nipple	27. Chemical tank mouth ring	28. Chemical tank mouth peg	29. Elbow	30. Check valve-1
31. Check valve packing	32. Check valve-2				

04. Carburettor

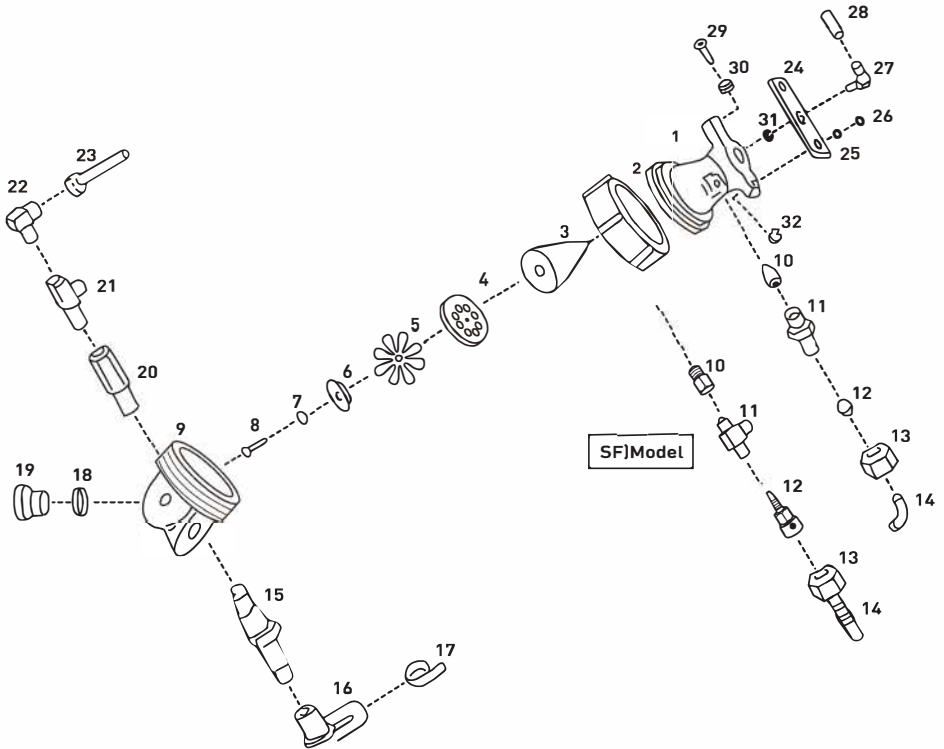

SFModel

1. Venturi	2. Screw seal	3. Cone shaft	4. Petrol valve board	5. Petrol valve	6. Petrol valve support
7. Spring washer	8. Bolt	9. Engine	10. Ejection nozzle	11. Nozzle	12. Ring
13. Nut	14. Engine upper pipe	15. Plug	16. Plug cap	17. Metal grip	18. O-ring
19. Engine rear peg	20. Reducer	21. Run tee	22. Elbow	23. Explosion pipe	24. Air gasket
25. Washer	26. Air Gasket Bolt	27. Air elbow	28. Extension hose	29. Air gasket bolt	30. Air gasket washer
31. Air gasket nut	32. Air gasket nut				

VECTOR FOG

UK OFFICE | KOREA OFFICE | US OFFICE

TEL: (UK)+44 (0)20 3808 5797 / (KOREA) +82 (0)70 4694 2489 / (US) +1 305 479 2301

Email: info@vectorfog.com / Website: www.vectorfog.com